

# SCHEMATIC DOOR ELEVATIONS

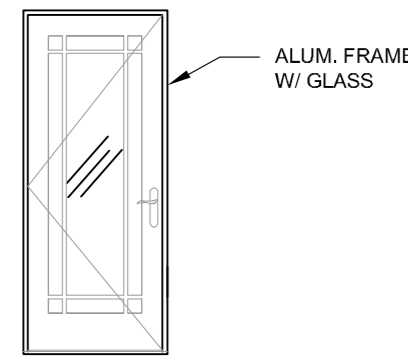

SINGLE ENTRY DOOR

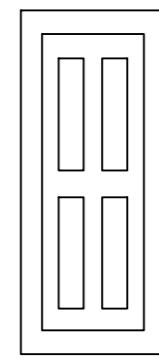

RAISED PANEL WOOD DOOR

**1** COMMERCIAL APP.  
SCALE: 1-1/2" = 1'-0"

**2** RESIDENTIAL APP.  
SCALE: 1-1/2" = 1'-0"

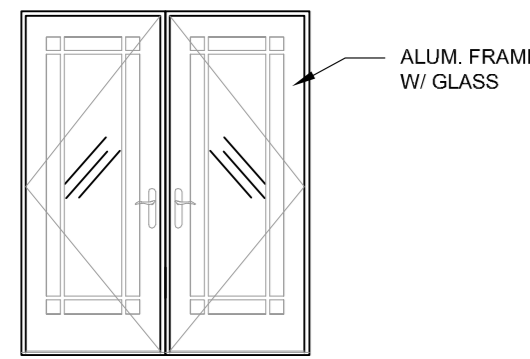

DOUBLE ENTRY DOOR

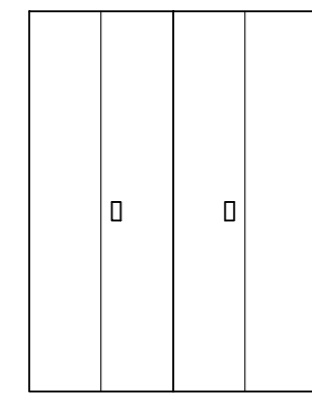

DOUBLE FOLDING WOOD DOOR

**3** COMMERCIAL APP.  
SCALE: 1-1/2" = 1'-0"

**4** RESIDENTIAL APP.  
SCALE: 1-1/2" = 1'-0"

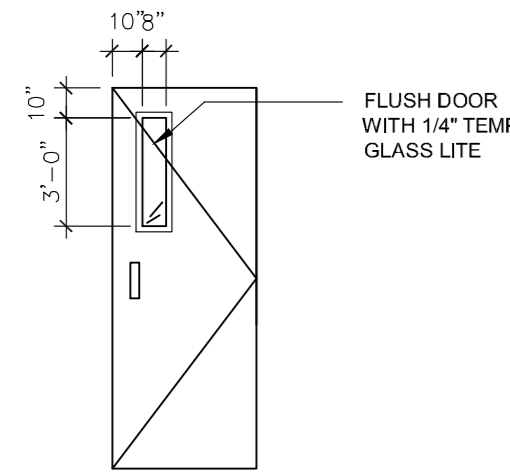

SINGLE DOOR W/ VISION PANEL

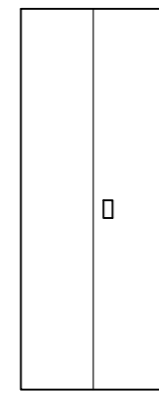

SINGLE FOLDING WOOD DOOR

**5** COMMERCIAL APP.  
SCALE: 1-1/2" = 1'-0"

**6** RESIDENTIAL APP.  
SCALE: 1-1/2" = 1'-0"

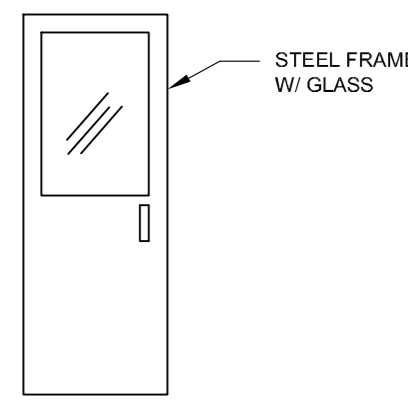

SINGLE ENTRY DOOR



SOLID CORE WOOD DOOR

**7** COMMERCIAL APP.  
SCALE: 1-1/2" = 1'-0"

**8** COMMERCIAL APP.  
SCALE: 1-1/2" = 1'-0"



SINGLE FLUSH DOOR W/LOUVER

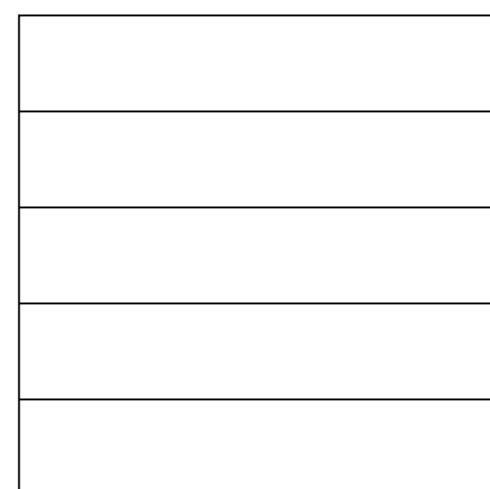

OVERHEAD DOOR

**9** COMMERCIAL APP.  
SCALE: 1-1/2" = 1'-0"

**9** RESIDENTIAL APP.  
SCALE: 1-1/2" = 1'-0"

# DOOR SCHEDULE

MARK	DOOR			STYLE	HARDWARE	RATINGS	REMARKS	SECURITY ACCESS MONITOR
	SIZE	THK.	MATERIAL					
A	2'-3"-0" x 7'-0"	1 3/4"	ALUMINUM/GLASS	3	****			****
B	3'-0" x 7'-0"	1 3/4"	ALUMINUM/GLASS	1	-		TRANSOM ABOVE DOOR	****
C	3'-0" x 7'-0"	1 3/4"	FIBERGLASS/GLASS	5	-			****
D	2'-4" x 6'-5"	1 3/4"	S.C. WOOD	9	-			****
E	3'-0" x 7'-0"	1 3/4"	STEEL/GLASS	7	-			****
F	3'-0" x 7'-0"	1 3/4"	STEEL/GLASS	5	-		TRANSOM ABOVE DOOR	****
G	3'-0" x 7'-0"	1 3/4"	S.C. WOOD	8	-			****
H	3'-0" x 7'-0"	1 3/4"	S.C. WOOD	9	-			****
I	3'-0" x 6'-5"	1 3/4"	S.C. WOOD	2	-			****
J	3'-0" x 6'-5"	1 3/4"	STEEL/GLASS	-	-		TRANSOM ABOVE DOOR	****
K	3'-0" x 6'-5"	1 1/2"	S.C. WOOD	6	-			****
L	2'-2" x 6'-5"	1 1/2"	S.C. WOOD	6	-			****
M	4'-0" x 6'-5"	1 1/2"	S.C. WOOD	4	-			****
N	2'-5" x 6'-5"	1 3/4"	S.C. WOOD	9	-			****
O	2'-5" x 6'-5"	1 3/4"	S.C. WOOD	2	-			****
P	5'-0" x 6'-5"	1 1/2"	S.C. WOOD	4	-			****
Q	2'-6" x 6'-5"	1 3/4"	S.C. WOOD	2	-			****
R	2'-5" x 6'-5"	1 1/2"	S.C. WOOD	6	-			****
S	2'-6" x 7'-0"	1 3/4"	STEEL/GLASS	-	-		TRANSOM ABOVE DOOR	****
T	3'-0" x 7'-0"	1 3/4"	S.C. WOOD	9	-			****
U	BY MANUFACTURER	-	STEEL	-	-			****

NOTES:  
ALL DOOR SELECTION TO BE VERIFIED BY OWNER \*\*\*\*\* HARDWARE SCHEDULE TO BE SELECTED BY OWNER \*\*\*\*\*

MANUFACTURER & FINISHES			
ITEM	MFR.	MODEL	FINISH
BUTTS	STANLEY OR EQUAL	BALL BEARING 5 KNUCKLE	626 or 605 VERIFY W/ OWNER
LOCKSET	SCHLAGE OR EQUAL	D-SERIES W/ RHODES LEVER	626 or 605 VERIFY W/ OWNER
CLOSER	LCN OR EQUAL	SURFACE MOUNTED	626 or 605 VERIFY W/ OWNER
THRESHOLD	REESE OR EQUAL	VARIES	ALUMINUM
BUMPER	HAGER OR EQUAL	232W	SATIN
H.M. FRAME	---	16ga. WELDED	PAINTED
H.M. DOOR	---	18ga. FACES	PAINTED

# WINDOW SCHEDULE

MARK	WINDOW			STYLE	HARDWARE	REMARKS
	MANUFACTURER	SIZE	MATERIAL			
W1	PELLA (OR EQUAL)	3'-0" x 5'-4"	ALUMINUM/GLASS	CASEMENT	BY OWNER	VERIFY WITH OWNER
W2	PELLA (OR EQUAL)	3'-0" x 2'-8"	ALUMINUM/GLASS	TRANSOM	BY OWNER	VERIFY WITH OWNER
W3	PELLA (OR EQUAL)	3'-0" x 1'-4"	ALUMINUM/GLASS	TRANSOM	BY OWNER	VERIFY WITH OWNER
W4	PELLA (OR EQUAL)	3'-0" x 6'-8"	ALUMINUM/GLASS	CASEMENT	BY OWNER	VERIFY WITH OWNER
W5	PELLA (OR EQUAL)	4'-0" x 5'-4"	ALUMINUM/GLASS	CASEMENT	BY OWNER	VERIFY WITH OWNER
W6	PELLA (OR EQUAL)	4'-0" x 2'-8"	ALUMINUM/GLASS	TRANSOM	BY OWNER	VERIFY WITH OWNER
W7	PELLA (OR EQUAL)	4'-0" x 1'-4"	ALUMINUM/GLASS	TRANSOM	BY OWNER	VERIFY WITH OWNER
W8	PELLA (OR EQUAL)	2'-0" x 6'-8"	ALUMINUM/GLASS	FIXED	BY OWNER	VERIFY WITH OWNER
W9	PELLA (OR EQUAL)	2'-0" x 1'-4"	ALUMINUM/GLASS	TRANSOM	BY OWNER	VERIFY WITH OWNER
W10	PELLA (OR EQUAL)	3'-0" x 4'-0"	ALUMINUM/GLASS	CASEMENT	BY OWNER	VERIFY WITH OWNER
W11	GLASS BLOCK	3'-0" x 9'-0"	GLASS BLOCK	FIXED	-	-

NOTES:  
ALL WINDOW SELECTION TO BE VERIFIED BY OWNER

# ROOM FINISH SCHEDULE

MK	ROOM	FLOOR				BASE		WALL		CEILING		REMARKS
		CARPET - CPT-1	HARD WOOD (BY OWNER)	12X12 CERAMIC TILE - CT-1	12X12 QUARRY TILE - QT-1	4X4 CERAMIC BASE CB-1	4X4 MARBLE BASE MB-1	4X4 QUARRY TILE BASE QB-1	PAINTED GWB P-1	2X2 CERAMIC TILE - CT-2	VINYL WALL COVERING - WC-1	
090	ENTRY FOYER											13'-6"
091	REAR STAIR											VARIES
092	CORRIDOR											13'-6"
093	ELEVATOR											-
094	EQUIP. ROOM											-
095	STORAGE											-
100	BASEMENT											SEE DWGS
101	COMMERCIAL SPACE											13'-6"
102	COMMERCIAL BATHROOM											13'-6"
103	UTILITY ROOM											13'-6"
200	LIVING ROOM											9'-10"
201	DINING ROOM											9'-10"
202	KITCHEN											9'-10"
203	BEDROOMS											9'-10"
204	MASTER BATHROOMS											9'-10"
205	WALK IN CLOSET											9'-10"
206	COMMON BATHROOM											9'-10"
207	MECHANICAL ROOM											9'-10"
208	LAUNDRY ROOM											9'-10"
209	CORRIDOR											9'-10"
210	BALCONY											9'-10"
300	LIVING ROOM											9'-10"
301	DINING ROOM											9'-10"
302	KITCHEN											9'-10"
303	ALCOVE											9'-10"
304	LAUNDRY ROOM											9'-10"
305	COMMON BATHROOM											9'-10"
306	MECHANICAL ROOM											9'-10"
307	BEDROOMS											9'-10"
308	MASTER BATHROOM											9'-10"
309	WALK IN CLOSET											9'-10"
310	NORTH WEST BALCONY											-
311	NORTH EAST BALCONY											-
312	SOUTH WEST BALCONY											-
313	SOUTH EAST BALCONY											-

NOTES:  
VERIFY ALL STYLES AND COLOR WITH OWNER

# FINISH LEGEND

MARK	DESCRIPTION	LOCATION	MANUFACTURER	MODEL #	NOTE:
<b>BATHROOMS</b>					
WC	WATER CLOSET	ALL BATHROOMS	KHOLER	XXX-XXX	TO BE VERIFIED BY: ROBIN CERNA, OWNER
BT-1	BATH TUB	MASTER BATHROOM	KHOLER	1144-H-O	TO BE VERIFIED BY: ROBIN CERNA, OWNER
BT-2	BATH TUB	COMMON BATHROOM	KHOLER	1357-G-96	TO BE VERIFIED BY: ROBIN CERNA, OWNER
SHW	SHOWER	MASTER BATHROOM	KHOLER	R10333-4S-CP	TO BE VERIFIED BY: ROBIN CERNA, OWNER
LAV	LAVATORY	MASTER BATHROOM	CHEVALI	CMB5007	VERIFY LOCATION WITH ROBIN CERNA, OWNER
LAV	LAVATORY	COMMON BATHROOM	CHEVALI	CMB5002	VERIFY LOCATION WITH ROBIN CERNA, OWNER
VAN	VANITIES	COMMON BATHROOM	PEGASUS TRANSITIONAL HAVEN	TREA3022	TO BE VERIFIED BY: ROBIN CERNA, OWNER
LITE-1	LIGHTING FIXTURE	MASTER BATHROOM	PROGRESS LIGHTING WESTEND	10502	TO BE VERIFIED BY: ROBIN CERNA, OWNER
LITE-2	LIGHTING FIXTURE	COMMON BATHROOM	PROGRESS LIGHTING WESTEND	P3084-09	TO BE VERIFIED BY: ROBIN CERNA, OWNER
<b>KITCHENS</b>					
K-FC-1	FAUCET	KITCHENS, 2 & 3 FLOORS	KHOLER	15162-L-CP	TO BE VERIFIED BY: ROBIN CERNA, OWNER
K-FC-2	FAUCET	KITCHEN, 4 FLOOR	GROEHE	GRO-32-071	TO BE VERIFIED BY: ROBIN CERNA, OWNER
SNK	SINK	KITCHEN	ELKAY	ELUHFS2816	TO BE VERIFIED BY: ROBIN CERNA, OWNER
FRDG	REFRIGERATOR	KITCHENS	MAYTAG	MFB256AEB	TO BE VERIFIED BY: ROBIN CERNA, OWNER
DSP	WASTE DISPOSAL	KITCHENS	MAYTAG	DFC5500AAX	TO BE VERIFIED BY: ROBIN CERNA, OWNER
<b>LIVING ROOM / DINING ROOM</b>					
C-FAN	CEILING FAN	LIVING ROOM	MYNKA FLITA 56"	47219	TO BE VERIFIED BY: ROBIN CERNA, OWNER
F-PL	FIRE PLACE	LIVING ROOM	BY OWNER	XXX-XXX	TO BE VERIFIED BY: ROBIN CERNA, OWNER
LITE-3	LIGHTING FIXTURE	LIVING ROOM / DINING ROOM	BY OWNER	XXX-XXX	TO BE VERIFIED BY: ROBIN CERNA, OWNER
<b>UTILITY ROOM</b>					
WSH	WASHING MACHINE	UTILITY ROOM	BY OWNER	XXX-XXX	TO BE VERIFIED BY: ROBIN CERNA, OWNER
DRY	DRYING MACHINE	UTILITY ROOM	BY OWNER	XXX-XXX	TO BE VERIFIED BY: ROBIN CERNA, OWNER
<b>EXTERIOR &amp; MISC.</b>					
HB	HOSE BIB	EXTERIOR WALL	ARROWHEAD	455	CHROME PLATED FREEZE PROOF



PO Box 417  
Naperville, IL, 60566  
tel: (773) 557-9555  
tel: (630) 550-2482  
fax: (630) 563-2817  
@: wedothat@kbppartnership.com

PROJECT NAME:  
3124-3126 N. KEDZIE AVE.  
MIXED USE BUILDING

PROJECT ADDRESS:  
3124-3126 N. KEDZIE AVE.  
CHICAGO, ILLINOIS

SHEET TITLE:  
**SCHEDULES**

REVISIONS:

PRELIMINARY, NOT FOR CONSTRUCTION

I hereby certify that this plan, specification, or report was prepared by me or under my direct supervision and that I am a duly licensed Architect under the laws of the state of Illinois.

REGISTRATION NO. DATE:

ISSUE FOR PERMIT:  
PENDING

This drawing is the sole property of KBP, Inc. and is protected under US copyright law and the Architectural Works Protection Act of 1990. The copy of this drawing and/or distribution to unauthorized personnel or construction of the structure depicted herein without express written consent of KBP, Inc., would constitute infringement of KBP, Inc. The recipient of this drawing acknowledges and agrees that the ownership of the drawing and all other right, title, and interest therein, including without limitation, all rights under US Copyright and other intellectual property law, are retained by KBP, Inc.  
COPYRIGHT © 2007  
ALL RIGHTS RESERVED

SHEET NUMBER: DATE: 03/26/2007

DRAWN BY: SC.1 CHECKED BY: